

1218, 1319, 1420 & 1521 Style Steel Safe-T Valve Service Tee Installation Instructions Threaded Inlet x Compression Outlet for PE Pipe

1. Verify that the compression outlet on the service tee is the correct size for the polyethylene (PE) pipe. Verify the SDR (or wall thickness) of the pipe matches the SDR (or wall thickness) stamped on the end of the stiffener.
2. Apply thread sealant to inlet threads of the tee
3. Screw the tee into the mating female pipe thread.
4. Make the service connection. See other side for outlet assembly instructions.
5. To assure proper assembly and to comply with 49 CFR 192 Subpart J—Test requirements, the joint shall be leak tested.
6. Using proper size adapters, secure control chamber of gate valve to tee.

IMPORTANT

For use on:
Polyethylene (PE) gas pipe meeting the requirements of ASTM D 2513

Pressure Rating: Designed to meet or exceed pressure rating of PE pipe per 49 CFR Part 192 and ASTM D 2513

Operating Temperature: -20 to 140° F

Material: Carbon Steel

Body Size	Adapter #
3/4" IPS	23-7317-02
1" IPS	23-7317-01
1 1/4" IPS	23-7317-00

7. For drilling operation, refer to drilling machine manufacturer's instructions and your companies qualified drilling procedures. Drilling machines such as TD-101 and TD-12 have been used with Continental Safe-T Valve Tees.
8. After the drilling operation has been completed, install the valve stem in the tee using CI pn# 23-7216-00 insertion adapter or equal. This insertion adapter has been designed to work with the TDW Speed tapper.
9. After the valve stem has been installed into the tee, remove the gate valve and size adapter.
10. Apply thread sealant and install pipe cap leak tight.

Compression Outlet for PE Pipe Installation Instructions

1. Install the compression nut and seal ring onto the outlet. Do not tighten the compression nut.
2. Cut polyethylene pipe end square, deburr inside and outside, clean thoroughly to assure there is no dirt, grease, oil, etc. on assembly area of pipe.
3. Mark stab length on pipe (see examples for correct pipe or tubing size and corresponding stab length).

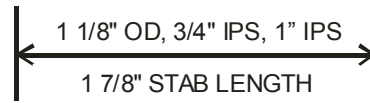
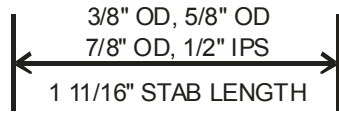

4. Insert the polyethylene pipe through the compression nut until it bottoms in the outlet. (See detail "A")
5. Tighten compression nut until it bottoms on shoulder (metal to metal). (See detail "B") The stab length line should be no more than 3/16" from face of the compression nut.
6. If the stab length line is more than 3/16" from the face of the compression nut, disassemble the joint and repeat steps 1 through 5.

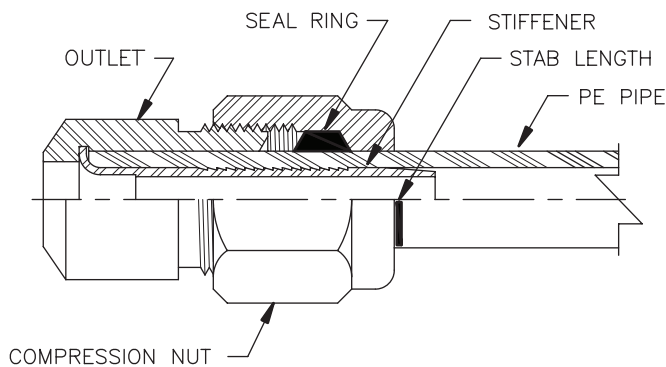

DETAIL "A"

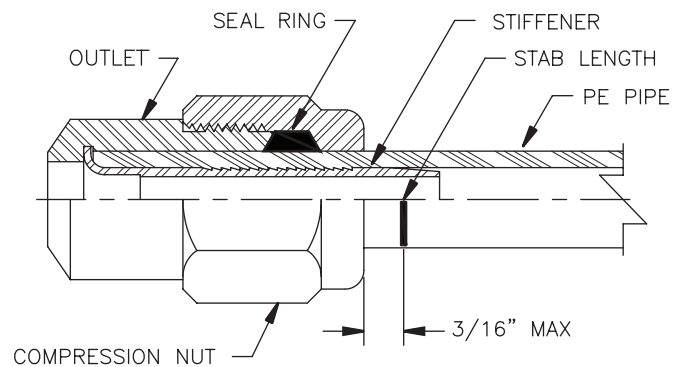

DETAIL "B"

NOTE: It is advisable to limit shear at main connections. In this regard, your company's policies should be followed. For further information, reference; ASTM D 2774 Standard Practice for Underground Installation of Thermoplastic Pressure Piping; Code of Federal Regulations, Title 49, Transportation Part 192; AGA Plastic Pipe Manual and/or The Guidance Manual for Operators of Small Gas Systems by the U.S. Department of Transportation.